

m e n , i d e a s , t e c h n o l o g i e s



checkweigher
checkweigher
checkweigher

30D3 - 31D3





checkweigher

30D3 - 31D3

Mod.30D3, 31D3V and 31D3L equipment

- Digital electronics with alphanumeric graphic display panel
- Electronic self-calibration device
- Production data handling according to current regulations
- Speed adjustable from keypad
- Mobile average function
- 100 storable product programs
- RS232 serial port
- Separated control module
- Photocell controlling obstructions down the line
- Photocell controlling storage unit up the line

Mod.30D3, 31D3V and 31D3L accessories

- Expulsion systems
- Reject management systems
- Feed-back function
- 24- columns panel printer
- Data collection via network
- Conformity with standards ISO-FDA-HACCP

Technical specifications

	mod.31D3V	mod.31D3L	mod.30D3
Capacity	1.500 g	2.000g	5.000g
Linear speed	up to 110 m/1'	up to 75 m/1'	up to 75 m/1'
Output	up to 600 PPM	up to 300 PPM	up to 300 PPM
Display division	0,5 g±1,0 g	0,5 g±1,0 g	0,5 g±1,0 g
Accuracy from	±1 g	±1 g	±1 g
Pneumatic supply	0.6 Mpa	0.6 Mpa	0.6 Mpa
Air consumption (for ejection)	1 NI	1 NI	1 NI
Power supply	230V 50/60Hz single-ph	230V 50/60Hz single-ph	230V 50/60Hz single-ph
Power consumption	1500 W	1500 W	1500 W
Version A	Aluminium+Stainless steel	Aluminium+Stainless steel	Aluminium+Stainless steel
Version B	Stainless steel AISI 316 IP65	Stainless steel AISI 316 IP65	Stainless steel AISI 316 IP65

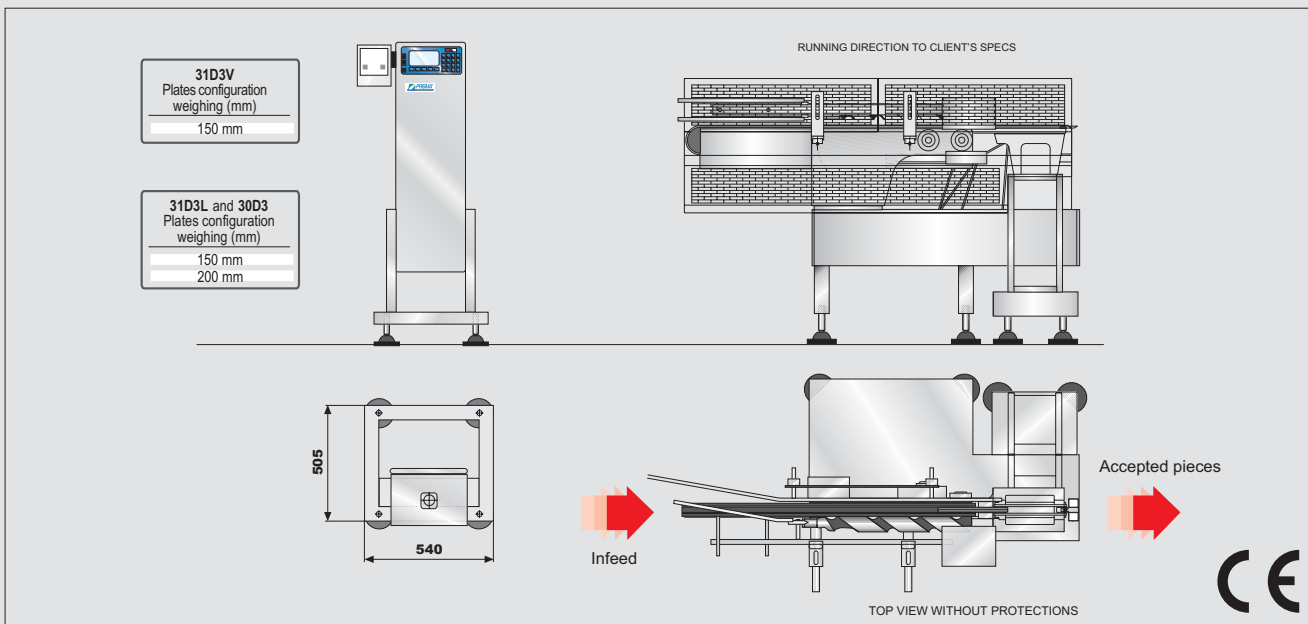

© 2002 - 2005 PRISMA INDUSTRIALE - REV 09/2005



Prisma Industriale S.r.l.

• Via La Bionda, 17 - 43036 Fidenza - Parma - Italy • Tel. +39 0524 527270 - Fax +39 0524 524142
 • www.prismaindustriale.com • info@prismaindustriale.com

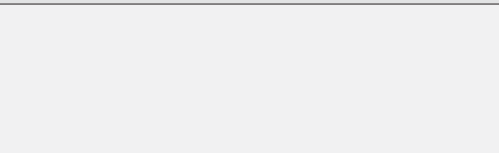

Data appearing in this brochure may be modified without prior warning.
 The machine used in this document is with all options