



checkweigher
checkweigher
checkweigher

01D3





checkweigher

01D3

Equipment

- Digital electronics with alphanumeric graphic display panel
- Electronic self-calibration device
- Production data management in conformity with the standards in force
- Speed adjustable from keypad
- Mobile average function
- 100 storable product programs
- RS232 serial port

Accessories

- Ejection systems
- Reject management systems
- Infeed and outfeed conveyors
- Wind-prevention tunnel
- Feed-back function
- 24-columns panel printer
- Open flap control device
- Data collection via network
- Conformity with standards ISO-FDA-HACCP
- Conveyors easily removable

Technical specifications

| | |
|--------------------------------|------------------------------------|
| Capacity | 600 g |
| Linear speed | up to 100 m/1' |
| Output | up to 500 PPM |
| Display division | 0,1 g - 0,2 g |
| Accuracy from | ± 0,1 g |
| Pneumatic supply | 0,6 Mpa |
| Air consumption (for ejection) | 1 NI |
| Power supply | 230V 50/60Hz single-phase |
| Power consumption | 700 W |
| Version | Stainless steel IP55 - IP65 - IP67 |

01D3

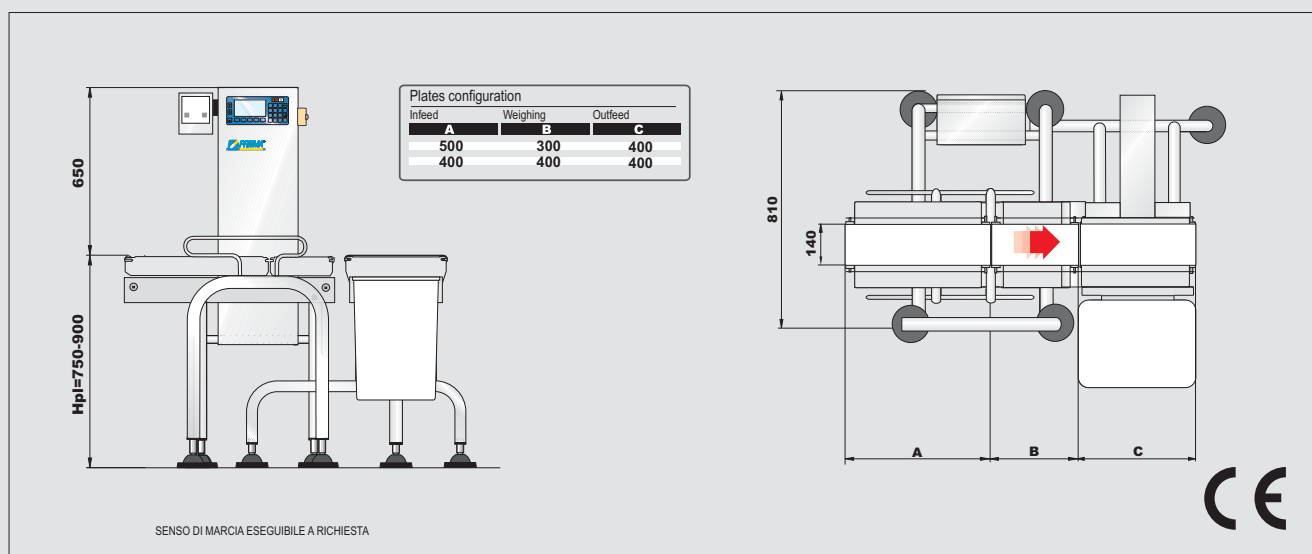

© 2002 - 2005 PRISMA INDUSTRIALE - REV 09/2005



Prisma Industriale S.r.l.

• Via La Bionda, 17 - 43036 Fidenza - Parma - Italy • Tel. +39 0524 527270 - Fax +39 0524 524142
 • www.prismaindustriale.com • info@prismaindustriale.com

Data appearing in this brochure may be modified without prior warning.
 The machine used in this document is with all options